

# PLGA MICROPARTICLE PRODUCTION STATION

Standard Pack, P/N: 1DPPL01

Automation Pack, P/N: O-SE-

PLGAAP-PCK



The Fluigent PLGA particle station is a robust and a high-quality system for producing monodispersed PLGA particles with flexibility to rapidly change particle sizes and production rates without interrupting production. Its performance results from the combination of Fluigent's high precision LineUP™ microfluidic pumps and the RayDrop, a breakthrough technology for high-quality particle production device.

## DESCRIPTION

When PLGA is used as active pharmaceutical ingredient (API) carrier, the size of the particle is critical as it affects drug release characteristics. It is then essential to produce highly monodispersed particle for drug release reproducibility. The most common production process of PLGA particles is solvent based and can involve hazardous solutions. Ethyl acetate has been referenced as a less hazardous solvent than other conventional ones (dichloromethane for instance). Specifically designed for **ethyl acetate solvent-based** particle formation, it shows highly reproducible results in term of **particle size distribution (CV <2%)**. This station is particularly suitable for researchers who want to test **different API encapsulation conditions** with **highly reproducible results**.

## STATION OPTIONS

	Standard pack	Automation pack	Full pack
Flow EZ™: High precision pump	✓	✓	✓
FLOW UNIT : High precision flow sensors	✓	✓	✓
RayDrop device	✓	✓	✓
A-i-O control Software	✓	✓	✓
P-CAP reservoirs	✓	✓	✓
Tubing, connector and fitting kits	✓	✓	✓
2-SWITCH™ valves		✓	✓
Automated device priming		✓	✓
MAT Software		✓	✓
Highspeed digital microscope			✓

# PRODUCT DATASHEET

## DETAILED CONTENTS

### Standard Pack

P/N: 1DPPL01

### Content

- 2 \* Flow EZ™ (2000 mbar)
- 1 \* Link
- 2 \* FLOW UNIT (M and L)
- 3 \* P-CAP (2 \* 15 mL and 1 \* 50 mL)
- 1 \* RayDrop
- 1 \* SupportRayDrop
- A-i-O Software
- Standard connector and tubing kit
- Flow EZ™ supply kit

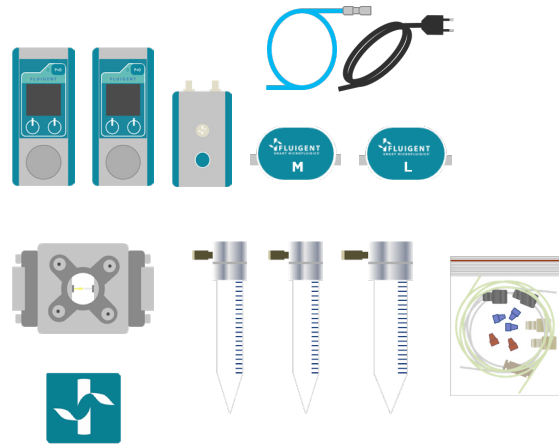

*Figure 1: PLGA microparticle production station, standard pack content*

### Set-up overview

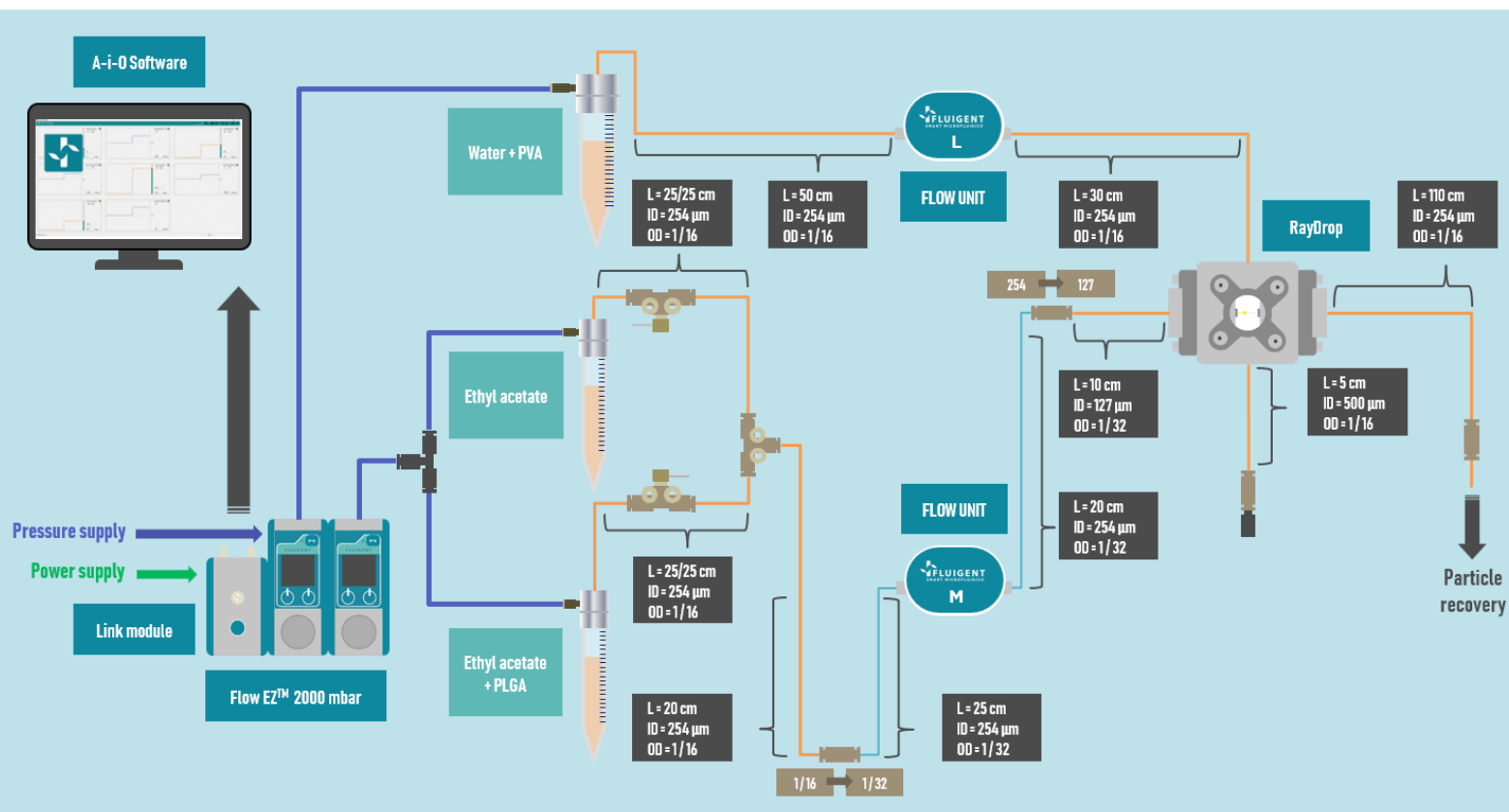

*Figure 2: PLGA microparticle production station, standard pack set-up*

# PRODUCT DATASHEET

## Automation Pack

P/N: O-SE-PLGAAP-PCK

### Content

- 2 \* Flow EZ™ (2000 mbar)
- 1 \* Link
- 2 \* FLOW UNIT (M and L)
- 3 \* P-CAP (2 \* 15 mL and 1 \* 50 mL)
- 2 \* 2-SWITCH™
- 1 \* Switchboard
- 1 \* RayDrop
- 1 \* SupportRayDrop
- A-i-O Software
- MAT Software
- Automation connector and tubing kit
- Flow EZ™ supply kit

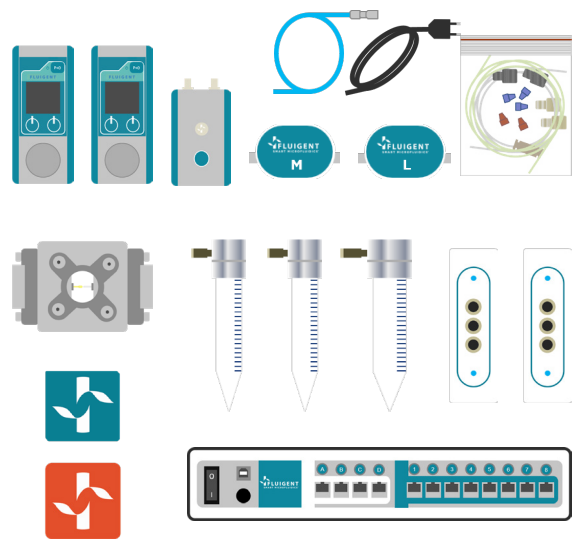

*Figure 3: PLGA microparticle production station, automation pack content*

### Set-up overview

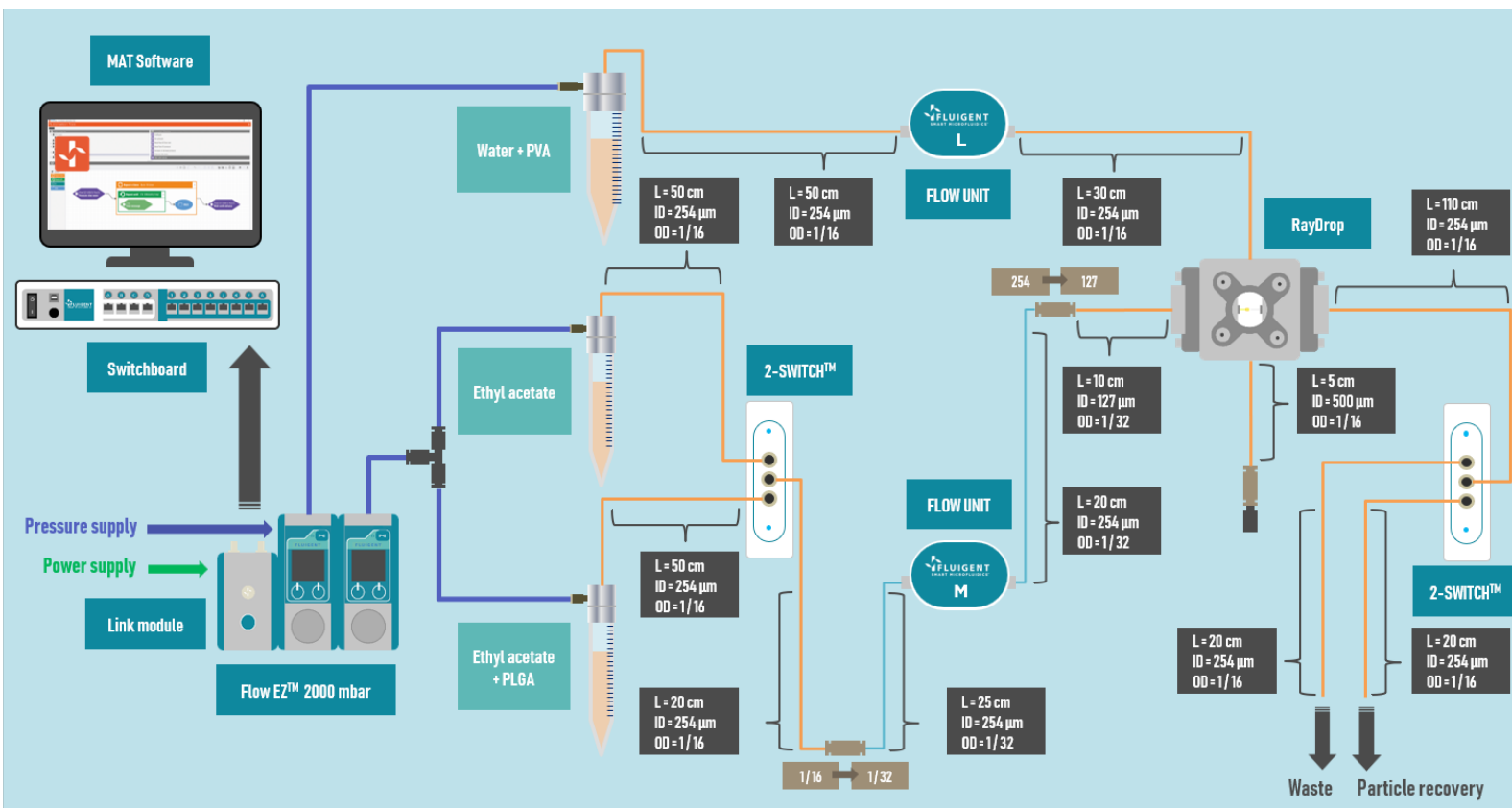

*Figure 4: PLGA microparticle production station, automation pack set-up*

# PRODUCT DATASHEET

## SETTING-UP THE STATION

Please refer to the **Good Practice Guide**.

## TECHNICAL SPECIFICATIONS

Particle production	
Dispersed phase	Resomer® RG 753 S, Poly(D,L-lactide-co-glycolide) ester terminated, Lactide: Glycolide 75:25, dissolved in ethyl acetate, mol wt 66,000-107,000
PLGA concentration used	2%, 5% and 10%
Continuous phase	Water + PVA
Droplet size range	60 µm to 120 µm
Particle size range*	20 µm to 50 µm
Production rate*	Up to 60 mg/h
Production frequency*	Up to 1000 Hz
Monodispersity	2%

Flow control	
Pumps**	Fluigent Flow EZ™ (2000 mbar)
Flow sensors**	Fluigent FLOW UNIT (M and L)
Automated valves**	Fluigent 2-SWITCH™

Imaging	
Microscope	Fluigent Digital high-speed microscope

Software	
Live control	Fluigent A-i-O
Automated control	Fluigent MAT
Imaging	Pixelink Capture Software

\*Depending on PLGA concentration (see **PLGA microparticle synthesis application note**)

\*\*For detailed specification: download **LineUP™ User Manual**, **ESS™ User Manual**.

## CONTACT

**日本代理店: 株式会社ASICON**

**Local distributor in Japan: ASICON Tokyo Ltd.**

[asicon-tokyo@asicon-tokyo.com](mailto:asicon-tokyo@asicon-tokyo.com)

[www.asicon-tokyo.com](http://www.asicon-tokyo.com)